



# CBH191



## FEATURES

- IP65 Stainless Steel Protection
- Large 22mm LCD backlit display
- Small compact design
- Wall bracket included
- 12v AC Adaptor & internal rechargeable battery operation
- Simple calibration
- RS232 as Standard
- Tare & Zero function
- Animal weighing
- Peak hold weighing
- Check weighing function
- Accumulation function
- NMI Trade Approved

## Stainless Steel Indicator



### DIMENSIONS mm

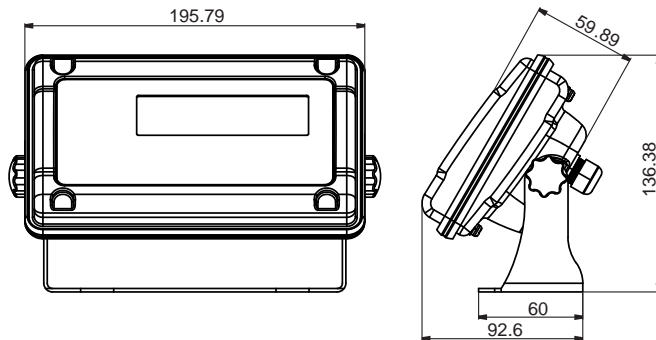

Distributed by:

Blank box for distributor information.